



# AQUALINC

AQUALINC RESEARCH LIMITED

---

## **Marlborough District Council** *Infiltration Gallery Investigation*

---

**Prepared for Marlborough District Council**

**Report No C14003/1**

**March 2014**



**Disclaimer:**

This report has been prepared solely for the benefit of the Marlborough District Council. No liability is accepted by Aqualinc Research Ltd or any employee or sub-consultant of this Company with respect to its use by any other person.

This disclaimer shall apply notwithstanding that the report may be made available to other persons for an application for permission or approval or to fulfil a legal requirement.

Quality Control			
Client:	Marlborough District Council		
Report reference:	Title: Marlborough District Council: Infiltration Gallery Investigation	No: C14003/1	
Prepared by:	Fraser Scales		
Reviewed by:		Approved for issue by:	Ian McIndoe
Date issued:	March 2014	Project No:	C14003

Document History			
Version: 1	Status: 1 <sup>st</sup> Draft	Author: FS	Reviewer: IM
Date: 15/11/13	Doc ID:	Typist: FS	Approver: IM
Version: 2	Status: 2 <sup>nd</sup> Draft – Client Issue	Author: FS	Reviewer: IM
Date: 17/1/14	Doc ID: Infiltration Gallery Recommendations.docx	Typist: RG	Approver: IM
Version: 3	Status: Final	Author: FS	Reviewer: VW
Date:	Doc ID: Infiltration Gallery Investigations Final.docx	Typist: FS	Approver: IM

© All rights reserved. This publication may not be reproduced or copied in any form, without the permission of the Client. Such permission is to be given only in accordance with the terms of the Client's contract with Aqualinc Research Ltd. This copyright extends to all forms of copying and any storage of material in any kind of information retrieval system.

# TABLE OF CONTENTS

	Page
<b>1 Introduction .....</b>	<b>1</b>
1.1 Infiltration Galleries .....	1
1.2 The Role of Infiltration Galleries .....	1
1.3 Principles of Infiltration Galleries .....	2
1.4 Project Background.....	2
1.5 Purpose and Scope of Investigation.....	3
<b>2 Literature Review .....</b>	<b>3</b>
2.1 Infiltration Gallery Design .....	3
2.1.1 Geotechnical Design.....	4
2.1.2 Hydraulic Design.....	6
2.1.3 Operation and Maintenance .....	8
2.2 Gallery Non-performance and Failures.....	10
2.2.1 Instantaneous Failure .....	10
2.2.2 Degenerative Failure.....	11
2.3 Riverbed Construction and the Environment .....	13
2.3.1 Silt.....	13
2.3.2 Pumping .....	13
2.3.3 Exposed Ground .....	13
2.3.4 Construction Works.....	14
2.3.5 Construction Materials.....	14
2.3.6 Waste Management .....	14
<b>3 Methodology.....</b>	<b>15</b>
3.1 Questionnaire.....	15
3.2 Interviews .....	16
3.3 Method of Analysis.....	16
<b>4 Results .....</b>	<b>17</b>
4.1 Questionnaire Supplemented by Site Visits and Interviews .....	17
4.1.1 Background Details .....	17
4.1.2 Gallery Performance.....	17
4.1.3 Performance Factors.....	19
4.1.4 Frequency of Maintenance.....	21
<b>5 Discussion .....</b>	<b>23</b>
5.1 Infiltration Galleries in the Marlborough District .....	23
5.2 Gallery Failures in the Marlborough District .....	24
5.3 Galleries and the Environment .....	26
5.4 Water Supply Options .....	27
<b>6 Conclusions and Recommendations .....</b>	<b>28</b>
<b>7 References .....</b>	<b>32</b>

## List of Tables:

Table 1:	Questionnaire design.....	15
Table 2:	Interview selective sample .....	16
Table 3:	Questionnaire sample population .....	17

## List of Figures:

Figure 1:	A typical (a) infiltration gallery and (b) embankment infiltration well.....	1
Figure 2:	Filter material grading.....	5
Figure 3:	Pipe perforations: (a) continuous, (b) machine-cut, (c) bridge .....	7
Figure 4:	Infiltration gallery/well performance over time .....	9
Figure 5:	Instantaneous failure mechanisms: (a) bed scour and undermining, (b) embankment failure, (c) structural failure, (d) mechanical failure .....	10
Figure 6:	Infiltration packs: (a) naturally developed, (b) well graded, (c) poorly graded ...	12
Figure 7:	Gallery performance .....	18
Figure 8:	Factors affecting gallery performance .....	20
Figure 9:	Washed infiltration pack material.....	21
Figure 10:	Presence of clay .....	21
Figure 11:	Frequency of routine maintenance and rehabilitation.....	22
Figure 12:	Gallery conduit with machine cut perforations .....	26
Figure 13:	Discharge during a gallery test .....	27

# 1 INTRODUCTION

## 1.1 Infiltration Galleries

Infiltration galleries are used to encourage and accelerate the process of groundwater recharge by allowing water to naturally infiltrate the riverbed material. Gallery systems harvest river water through a network of collection pipes installed under or beside the riverbed. Infiltration galleries can be classified as either:

- A riverbed infiltration gallery – galleries that run under a riverbed or water body (Figure 1(a)) ; or
- An embankment infiltration gallery – galleries that run parallel to riverbed or water body (Figure 1(b)).

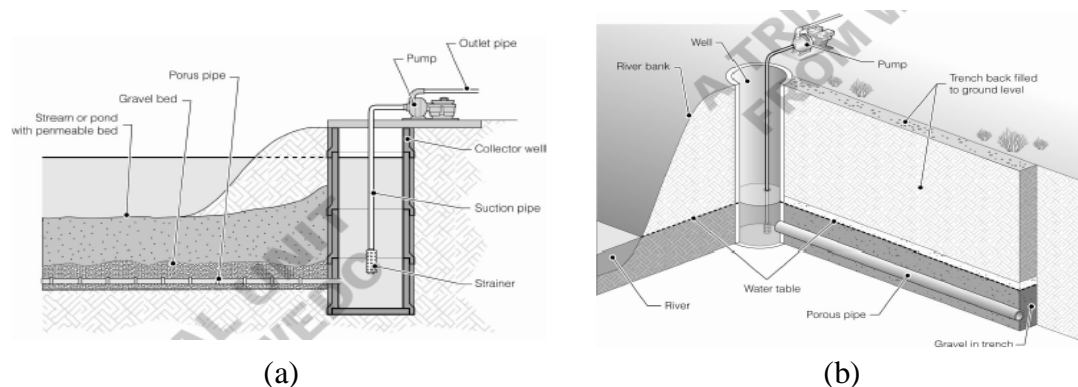

Figure 1: A typical (a) infiltration gallery and (b) embankment infiltration well

Many variations exist in practice. Some riverbed galleries run under flowing surface water, while others rely on intercepting groundwater. Some consist of a single porous pipe, while others utilise multiple pipes. Regardless of their specific design, they perform like large diameter horizontal wells and are frequently utilised where water depth to a confining layer is limited.

## 1.2 The Role of Infiltration Galleries

Infiltration galleries should be seen as one of a number of techniques available for diverting/abstracting river water. Natural filtration is one of the main benefits of an infiltration intake, and is used to reduce water quality variance. Galleries can eliminate the need for fish protection screens, and therefore the issues with screen cleaning of surface intakes. Galleries are also perceived to be less susceptible to flood damage because the installation is not directly exposed to the main body of flow.

Infiltration galleries may not be appropriate for every situation encountered. For example, local conditions may inhibit their use if the infiltration capacity of the ground is low, if the risk of high energy storm events is high, or if the river system is highly unstable and significant remedial works will be required to divert the course of the river over the galleries.

### 1.3 Principles of Infiltration Galleries

The availability of groundwater is heavily dependent upon soil structure and, in particular, the volume of voids. Gravels and coarse sands will allow water to flow through the voids relatively easily in comparison to fine grained soils, such as silts and clays. The ease in which water can pass through the soil structure is expressed in terms of permeability.

Highly permeable and fully saturated soils are termed '*aquifers*'. An '*aquiclude*' is a term used to describe saturated soils with a low permeability. Aquifers can also be unconfined or confined. An unconfined aquifer is exposed to the atmosphere, whilst a confined aquifer is overlain with a relatively impermeable stratum.

Infiltration gallery systems are a form of river intake structure used to collect and distribute river water from alluvial/shallow aquifers. As the system is usually housed below the water table, it can also be considered a direct recharge system. The governing principles, used in the design of gallery systems, are similar to those used for the design of drainage systems. In essence, the proficient designer will seek to effectively and efficiently facilitate the movement of water through the soil structure, without compromising the surrounding environment.

For an infiltration gallery system to be effective, the surface water body must be close enough to the structure and have a surface area large enough to allow processes (such as infiltration and seepage) to occur. The size of the required recharge area (A) is dictated by the hydraulic properties of the soil, namely its permeability (k), and the required discharge (Q), as stipulated by Darcy's law.

$$Q = Aki$$

### 1.4 Project Background

Buried gallery intakes are commonly used by irrigators in Marlborough to abstract water for irrigation, particularly where fine sediment stays in suspension for long periods, even during times of low flows. Gallery intakes may be in-stream, in riparian gravels, or on a diversion from the river. Water may also be abstracted from sub-surface flows in seemingly dry transient streams. From a user's perspective, gallery intakes provide natural filtration, which is widely considered to be more effective than mechanical filtration systems.

The operational lives of galleries in the Marlborough region have been highly variable; some have maintained the required flow for many years, others have experienced frequent reductions in yield, while some have experienced sudden and complete gallery failure. Failure inevitably occurs during periods of peak demand, which can have devastating consequences on the user's activities and on the environment.

Any form of construction or maintenance activities in or near surface water has the potential to cause pollution or impact on the quality of surface water. Some galleries have had to undergo major maintenance or be completely reinstalled to reinstate the water supply. If the value of water is high (i.e. irrigation), the user may have no choice but to immediately conduct remedial works, regardless of the environmental implications.

## 1.5 Purpose and Scope of Investigation

The objective of this investigation is to provide support in developing a set of guidelines for contractors who install and maintain infiltration galleries, and for irrigation system operators who use galleries to abstract water for irrigation, stock water and industry, with the aim of minimising the effects of construction and maintenance of galleries on in-stream biota and the riverbed environment.

In order to achieve the overall aim, the research objectives will be:

- To identify the cause of past gallery non-performance and failures;
- To determine possible solutions to the problems; and
- To prepare a set of guidelines for design, construction, maintenance and operation of galleries that will minimise the effects of the in-stream and riverbed environments.

## 2 LITERATURE REVIEW

The literature review comprises three sections. The first section is a review of current design practices, standards and codes of practice objectives to evaluate the comprehensibility and practicality of current guidelines and identify areas of design uncertainty. The second is identification of known gallery failure mechanisms. This section specifically focuses on the failure of infiltration packs. The final section is a review of the current pollution prevention methods for works in and around water.

### 2.1 Infiltration Gallery Design

Infiltration has been seen as one of a number of techniques available to engineers for abstracting surface water. It comes in a variety of forms, either running parallel to the river or directly underneath the riverbed, where the system is usually under the direct influence of surface water (WEDC, 2011). In principle, the design fundamentals resemble that of an infiltration drainage system.

Over recent years, the drainage sector has moved towards more sustainable ‘soft’ solutions that seek to simulate naturally occurring processes. This has led to the development of a broad body of knowledge in the field of groundwater design. However, there are some significant differences, particularly when pumps are to be used to abstract water from the gallery.

There is an apparent gap between the abstraction techniques being exercised and the industry’s recognised body of knowledge. While the use of infiltration systems has been widely endorsed by industry practitioners in the field of drainage, there is a distinct lack of comprehensive technical design guidance and industry understanding on the use of infiltration systems for the purpose of abstracting and diverting surface water. Guidelines for the construction of infiltration systems are available in the form

of AS-NZS 3500-3: *Plumbing and Drainage: Storm Water Drainage*. However, the guide places an emphasis on drainage, and is technically limited.

Driscoll (1986) suggests that prior to initiating any detailed design work, the feasibility of using an infiltration system should be considered. This is to ensure that there is no fundamental reason as to why an infiltration gallery will not be appropriate. For smaller schemes, only a small qualitative assessment may be required. However, for larger projects, some form of preliminary design work and costing should be developed and analysed.

The feasibility analysis will vary, depending on the particular abstraction problem under consideration. However, in general, Driscoll (1986), Falkland (1999) and Lauterjung & Schmidt (1989) suggest that the following points ought to be given due consideration, and should address the more frequently encountered difficulties:

- What is the daily volume of river water that must be abstracted?
- What would the consequences of a large storm event be on the installation?
- What are the alternatives to installing an infiltration gallery?
- What is the likely environmental impact of the proposed project?
- Are there any geotechnical issues associated with the soil type that may prohibit the use of infiltration techniques?

The design of the infiltration gallery needs to address a number of critical issues. The three most critical aspects of the design process are the geotechnical, hydraulic and future maintenance considerations. For the purpose of this investigation, legislative issues surrounding resource and building consents have been considered beyond the scope of this report.

### **2.1.1 Geotechnical Design**

According to CIRIA (2007) and Azizi (2007), the process of geotechnical assessment should include an evaluation of the underlying strata and the impact of disturbances to the riverbed. Seepage of water through the surrounding material can also induce erosion and transport of the soil particles. This can facilitate sediment entry into the system, which can subsequently cause an infiltration pack to become blinded by particle ingress. The choice of granular fill used to backfill the gallery trench needs to be sized accordingly, with the rate of infiltration being a compromise between the degree of particle removal and the need to achieve a specific yield for a given head. Typically, locally available graded clean stone/rock is considered acceptable. However, this 'ad-hoc' approach is associated with high levels of uncertainty surrounding particle clogging of the infiltration pack (Lauterjung & Schmidt, 1989).

For rivers with a high sediment concentration, significant emphasis should be placed on the design of a suitable infiltration pack in an effort to reduce the risk of clogging and the need for frequent and costly maintenance. Rip rap can be used on the riverbed to generate flow turbulence, which in turn will reduce the velocity of the water over the surface of the intake. It is important to note that while this does aid vertical drainage, the bed shear stress will also decrease. Chadwick et al. (2004) argues that if the bed shear stress is less than the threshold for sediment motion, particle accretion will occur in and around the vicinity of the intake, which will further increase the risk of clogging.



The sub-surface infiltration pack should contain one or two distinct layers, depending on the grading of the bed material. If required, CIRIA (2007) recommends the first layer to comprise of a highly porous, clean stone or rock fill. The purpose of this layer is to provide storage, which is used to increase the rate of vertical drainage and to provide a stable interface between the backfill and the finer filter pack material. The final layer, which is also used to bed the porous pipe, should encompass a filter that controls the flow of water to prevent the erosion of the surrounding natural bed material (Azizi, 2007). To fulfil this requirement, the fill needs to be sized according to the grain size distribution of the natural soil.

The fill must comprise of enough large particles to safeguard free drainage of water, and a suitable percentage of smaller particles to impede the movement of the riverbed's natural material. The filter stability at the interface of the two materials should also be considered as part of the design process (CIRIA, 2007). Granular materials with permeability in excess of 0.1 m/s may appear as an attractive solution due to their ability to facilitate the required discharge. However, the flow through the fill is usually turbulent, as opposed to laminar flow for finer fills, and can induce erosion of the surrounding bed material. It is argued that the particle size distribution curve should be similar in form to that of the natural material, against which the filter is to be applied to prevent gaps in the grading.

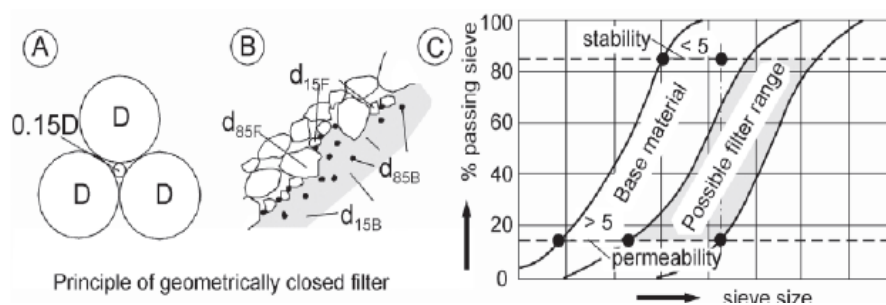

Figure 2: Filter material grading

There are various, marginally different, methods and guides available for the design of soil filters. Azizi (2007) presents the following method that uses the grading curve of the extracted soil sample to determine the grading curve of the filter material. The solid particle sizes corresponding to 85%, 60%, 50%, 15%, 10% and 5% of percentage passing are represented by  $d_{85}$ ,  $d_{60}$ ,  $d_{50}$ ,  $d_{15}$ ,  $d_{10}$  and  $d_5$ . Subscripts  $f$  and  $s$  refer to *filter* and *natural soil*, respectively.

- a) To prevent the migration of the natural soils fine particles through the filter:

$$d_{15f} \leq 5 \times d_{85s}$$

- b) To ensure that the filter is more permeable than the soil:

$$d_{15f} \geq 5 \times d_{15s}$$

- c) To ensure good performance:

$$4 \leq d_{60f}/d_{10f} \leq 20 \text{ and } d_{Maxf} \leq 50 \text{ mm}$$

d) To ensure adequate drainage of water:

$$d_{5f} \geq 0.0750 \text{ mm}$$

e) To prevent any segregation of the filter material:

$$d_{50f} \leq 25 \times d_{50s}$$

f) Where the filter is to be placed against a screen mesh:

*$d_{85f}$  should not be less than twice the mesh size*

g) The grading curve of the natural soil should be limited to a maximum particle size:

$$d_{Maxs} \leq 19 \text{ mm}$$

CIRIA (2007) suggests that there is a general consensus within industry that for a granular filter where high permeability is the primary requirement, the following general expression provides a suitable rule of thumb:

$$D_{15f}/D_{15s} > 4 \text{ to } 5$$

In some instances, the granular fill can be separated from the surrounding material by a suitable geotextile fabric to prevent the migration of fines into the infiltration pack (Jewell, 1996). However, it is largely accepted that geotextile fabric should never be wrapped around the outside of the perforated conduit, as it will be difficult and expensive to remove when it becomes clogged (Driscoll, 1986).

The general requirements of a geotextile filter are the same as those discussed for a granular filter. Consideration must be given to the ratio of fabric thickness and permeability; and not just the materials permeability, as with the infiltration pack. As a general rule, an appropriately specified geotextile is used when there is no significant pressure loss over the geotextile. A reduction in the fabrics permeability from clogging is also to be expected, and should be accounted for by using a long-term reduced value for the filter permeability (Jewell, 1996).

## 2.1.2 Hydraulic Design

The purpose of an infiltration gallery is to abstract river water effectively and efficiently from the ground. The hydraulic behaviour of the system is therefore a dominant feature in its design. For the purpose of hydraulic design, it should be assumed that the resultant infiltration from the river system has a 'block' nature (i.e. constant steady flow), although, in practice, riverbeds are subject to oscillating dynamic loads, which are influenced by a complex array of environmental factors.

A variety of factors will influence the final orientation and location of the screens. Driscoll (1986), Lauterjung & Schmidt (1989) and UNEP (2012) advise that these should include, but are not limited to, the following:

a) **Yield requirements:** Groundwater testing will determine if the sub-surface aquifer has a high enough transmissivity to enable demand to be met. Riverbed infiltration galleries will have a gross yield in the order of twice that of an embankment well.

- b) **Water quality requirements:** All infiltration systems will provide some form of water cleansing/purification. However, infiltration galleries are often associated with dirtier water than that abstracted from an embankment well.
- c) **Construction:** Generally, embankment wells are easier to construct, avoiding issues surrounding riverbed works.
- d) **Maintenance considerations:** Maintenance of a (below bed) infiltration gallery can often be difficult. If performance deteriorates with time, then the whole structure may have to be replaced. This may require the river flow to be diverted in addition to extensive ground works, which can be expensive. In contrast, embankment wells are associated with better access, and are less prone to clogging from river sediment.
- e) **Adjustment of channel form:** This is of interest to both geomorphologists and hydraulic engineers concerned with the short-term variations affecting sediment accretion, scour (channel stability) and bed-form topography, which can undermine hydraulic structures on the riverbed. A reduction in river stage, and thus the available head, will also lead to a reduction in yield.

The hydraulic properties and geometry of the materials used will also have a significant influence on the hydraulic performance of a gallery. It is common practice for slotted PVC or a porous no-fines aggregate concrete pipe to be used as the conduit (Howsam et al., 1995). Steel pipes benefit from a higher bearing capacity, but are prone to long-term corrosion. Perforations on the pipe can come in a variety of forms to suit the locality, but should not exceed 18-20% of the total pipe area in order to maintain the pipe's structural integrity. Figure 3 illustrates the most common forms of pipe perforation.

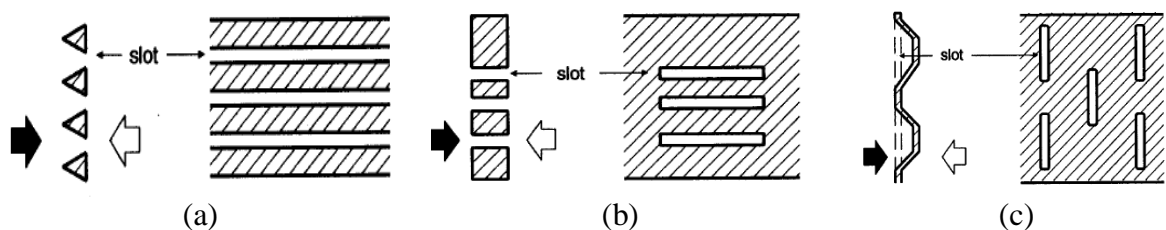

Figure 3: Pipe perforations: (a) continuous, (b) machine-cut, (c) bridge

Orifices should be sized to restrict the velocity of flow entering the conduit to below 0.03 m/s, with velocities inside the screen never exceeding 0.9-1.0 m/s (Driscoll, 1986). Every effort should be made to prevent the surrounding fill material from entering the system. The following equation can be used to calculate the screen entrance velocity:

$$V_e = \frac{Q}{\pi DLpb}$$

Where:  $V_e$  is entrance velocity (m/s)       $L$  is net length of screen  
 $Q$  is discharge (m<sup>3</sup>/s)                       $p$  is proportion of open area of screen

$D$  is diameter of screen (m)

$b$  is a blocking factor (usually 0.5)

Sommerville (2005) and CIRIA (1994) recommend that groundwater recharge should be sufficient enough to adequately maintain the required pump rate, and the resulting drawdown should never exceed the point at which the required net positive suction head for the pump is compromised. The depth of the trench will also be heavily dependent on the depth to the water table/saturated zone. Driscoll (1986) and the Canadian Ministry of Forests, Lands & Natural Resource Operations (2012) suggest that for an infiltration gallery, the screen should be buried at least 1.5 m below the riverbed, with a minimum of 0.3 m of infiltration pack material beneath the screen. For embankment wells, a minimum depth of 1.2 m below the static water level is also recommended.

For a given diameter of pipe, there is a limit to the length of gravity-induced drainage to maintain full pipe flow. The length of screen required for bed-mounted infiltration galleries is a function of the required discharge ( $Q$ ), permeability ( $K$ ), head ( $H$ ) and the distance from the riverbed to the centre of the screen ( $d$ ). The following formulas recommended by Driscoll (1986) can be used to approximate the required infiltration screen length:

$$L = \frac{0.366 Q \log\left(\frac{1.1d}{r}\right)}{0.25KH}$$

$$L = \frac{2r_0Q}{K(D^2 - d^2)}$$

**Bed-mounted infiltration systems**

**Embankment-mounted systems**

For embankment-mounted infiltration galleries, the screen length is a function of the permeability of the filter pack ( $K$ ), the depth of the trench below static water level, the total head while operating under drawdown conditions ( $d$ ), and the radius of the cone of depression ( $r_0$ ). The location of any pumping plant must be considered at an early stage. While water can be pumped from individual galleries, a gravity system feeding into a single shallow well can offer a more economical solution, provided a minimum grade of approximately 5% can be maintained.

### 2.1.3 Operation and Maintenance

Regardless of the complexity in design, every infiltration system will require some form of regular maintenance in order to sustain/preserve a specified level of performance. The design life of the structure is significantly influenced by the local ground conditions, in particular, the clogging of the surrounding infiltration pack (Azizi, 2007).

In theory, the use of a well-structured monitoring, operation and maintenance programme will reduce the need for system rehabilitation. Alternatively, a crisis management approach can be adopted whereby the operator will only respond to events as and when the system fails or reaches a point of unsatisfactory performance. In practice, most operators are happy to function between these two extremes (Lauterjung & Schmidt, 1989).

Rehabilitation is the process of restoring a system back to its original level of performance. In some instances, the difference between rehabilitation and maintenance is only the extent to which a technique needs to be applied. Figure 4

illustrates how regular maintenance can maintain peak performance, and how periodic system rehabilitation results in a gradual reduction in performance.

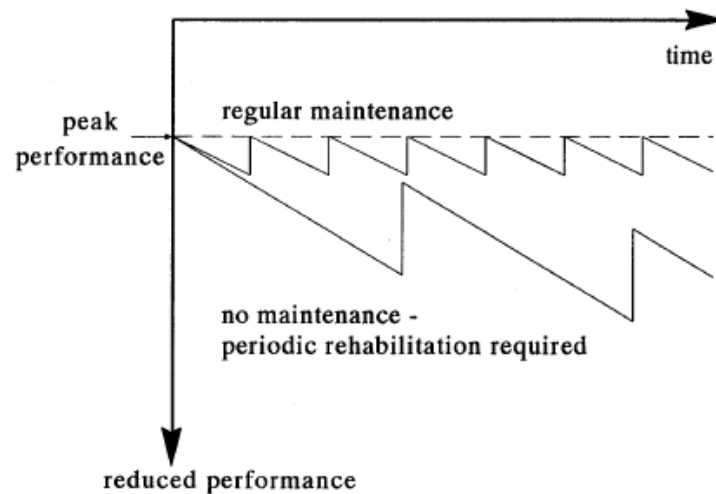

Figure 4: Infiltration gallery/well performance over time

Sediment accretion within or surrounding the infiltration trench will, over time, generate a zone of less permeable material. This will result in a reduction in discharge capacity and an increase in pore water pressures. Geotextile fabric has been used to protect the infiltration trench from particle ingress on some systems. However, the fabric will inevitably experience deterioration in permeability through clogging, as it restricts the migration of fines (CIRIA, 2007).

Incrustations attached to internal surfaces of the pipe/screen and deposits from the screen slots will need to be removed to rectify diameter reduction and frictional losses. This can usually be achieved either chemically or physically by backwashing at twice the pumping rate. The use of plastic pipes and fittings will reduce the need for this type of routine maintenance (Driscoll, 1986).

Rivers with high velocities benefit from the presence of migrating bed-forms. Fine particles with low fall velocities are entrained in suspension by the fluctuating vertical and horizontal components of fluid turbulence and transported along the river channel in suspension (Chadwick et al., 2004). This prevents/reduces 'armouring' of the riverbed in and around the vicinity of the infiltration trench, and helps maintain the required rate of infiltration needed to produce the desired yield. Surface water bodies with low velocities (i.e. lakes) are susceptible to high levels of particle deposition. The subsequent build-up of a relatively impermeable boundary will require routine maintenance to remove it from the intake vicinity to maintain the required rate of infiltration.

Various methods are available for the analysis of sediment transport, including the use of the Shields parameter, the Ackers-White total load formula, the Bagnold total load formula, and the Van Rijn method.

## 2.2 Gallery Non-performance and Failures

There are several situations where the use of an infiltration gallery or well may not be appropriate. This may be due to a low aquifer transmissivity, which will result in a low specific yield. High energy storm events and glacial melt will also cause rapid adjustments to channel form for some rivers, and can expose riverbed or embankment structures to scour and eventual undermining (Driscoll, 1986).

When considering the risk associated with the various types of infiltration gallery, it is helpful to enumerate the number of ways in which the components of the structure may be damaged, leading to eventual failure of the system. Failure has been categorised as either instantaneous or degenerative.

### 2.2.1 Instantaneous Failure

Instantaneous system failure occurs when a severe event causes catastrophic damage to the system that prevents it from performing its required function. The following is a summary of the potential instantaneous failure mechanisms detailed in Figure 5.

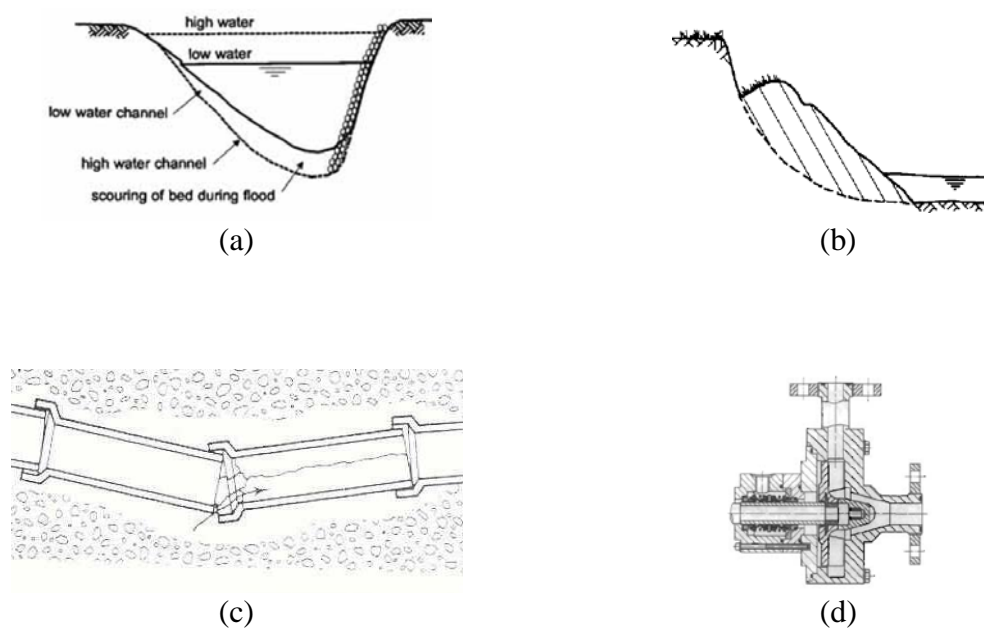

Figure 5: Instantaneous failure mechanisms: (a) bed scour and undermining, (b) embankment failure, (c) structural failure, (d) mechanical failure

#### **Bed scour and undermining**

Galleries that have been constructed on or close to the surface of the riverbed are at an increased risk of failure from scour. Bed-forms act as a self-regulating mechanism in rivers, ensuring efficient transport of both sediment and fluid. The riverbed's elevation and shape (roughness) are dynamic functions of the characteristics of the water flow.

As stream power increases (perhaps due to seasonal weather patterns), the bed shear stress increases approximately with the square of the mean velocity. The increase in

bed shear stress results in particle motion penetrating more severely into the riverbed, leading to the formation of large undulating bed-forms. The relative size of these protrusions into the river flow generates large vortices that are capable of suspending relatively large particles, increasing the rate of bed erosion and scour (Chadwick et al., 2004).

### **Embankment failure**

Embankments may fail at almost any time from natural processes such as surface erosion or toe scour. Additionally, the application of a sudden load to the bank may induce failure. Embankment failure is most frequent shortly after periods of prolonged heavy rain or high river stages. A well sited on an embankment prone to high levels of erosion is at risk of failing, as the embankment retreats towards the well (Hemphill & Bramley, 1989).

### **Structural failure of conveyance system**

A gallery system will be subjected to dynamic loading as a result of oscillating wave action and seasonal fluctuations in river stage. Plastic pipes must be accurately aligned, fully supported, and possess enough strength to resist various loading requirements. In addition to correctly sizing the pipe, good installation practice is also a necessity if the risk of structural failure is to be avoided (Lauterjung & Schmidt, 1989). Good compaction of side fill is more readily achieved in a narrow trench, and pipes then receive better support against squashing from loads above. While this form of failure is relatively uncommon, in the event of a failure, the cost of remedial action will be high.

It should be noted that while a narrow trench is beneficial in terms of dynamic loading, a wider trench allows more storage for silt settlement, keeps transport velocities lower and is easier to manage from a health and safety perspective.

### **Mechanical failure**

The primary purpose of a pump is to abstract water from a well or conduit. The reliability of the pump system will depend on an array of factors that will vary according to the pump's location, specification and type. Most of the factors influencing a pump's performance are directly or indirectly related to the amount of debris in the water, which may have increased in volume as the system degrades over time (Hamill, 2006). Particle abrasion wears pump impellers and removes protective finishes. If left untreated, corrosion will occur and the risk of failure will increase significantly.

## **2.2.2 Degenerative Failure**

The time taken for a substantial loss of performance to occur depends upon the nature of the bed material and the quantity of sediment that enters the system. Although there are a number of systems that have operated satisfactorily for long periods without any maintenance, infiltration systems will normally require maintenance of their surface intake and sub-surface infiltration pack to prevent a decline in yield. The following is a brief summary of the main potential degenerative failure mechanisms.

### **Root ingress**

Roots from trees and shrubs growing over or near to galleries can extend into filter packs and through pipe slots into gallery pipes. This is particularly an issue with

willows growing in the vicinity of galleries. In some cases, root growth can completely block gallery pipes, resulting in the need to dig up and clear the pipes. Trees and shrubs must be kept clear from gallery areas.

### **Aquifer failure**

One factor that will induce a gradual decline in yield and could subsequently lead to failure of the aquifer/saturated zone is dewatering from over-abstraction. There is also a high risk of exposing the pumping plant to issues surrounding net positive suction head and cavitation if excessive drawdown is experienced (CIRIA, 1994).

### **Infiltration pack failure**

One of the greatest risks of failure comes from the infiltration trench and conduit. Paradoxically, the subsystem associated with the lowest degree of reliability, due to the uncertainty surrounding ground conditions, is also the most problematic subsystem to rehabilitate and maintain.

The redistribution of fine particle matter through the infiltration pack can introduce the process of clogging into the system. Disturbances to the ground during construction and inter-mixing of the infiltration pack material with the surrounding soil can lead to the migration of fines from the formation into the infiltration pack. In certain situations, the individual permeability of the formation and gravel pack could be high. However, when combined, the velocity with which water can seep through the pores may be significantly reduced if there is a reduction in the voids ratio. This will result in a reduction in overall permeability (CIRIA, 2007).

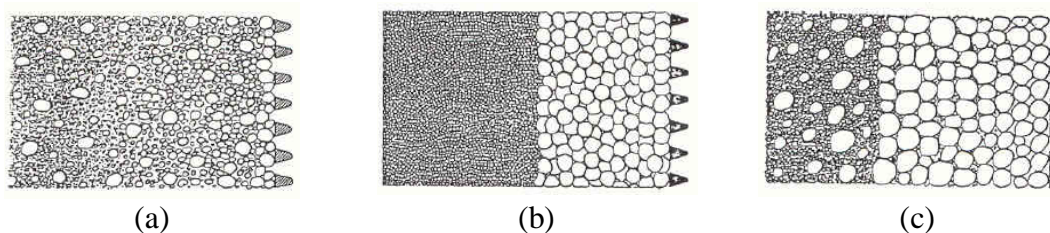

*Figure 6: Infiltration packs: (a) naturally developed, (b) well graded, (c) poorly graded*

### **Geotextile fabric failure (if present)**

Polymer reinforcement can fail in a number of ways. Physical damage includes tearing and punctures from poorly prepared backfill and/or bedding materials. However, the most common form of geotextile failure is from clogging resulting from biological or chemical build up due to poor or inadequate design. The retained particles or residuals can reduce the fabrics permittivity considerably, leading to eventual failure.

### **Conduit failure**

The conduit may become abraded if water with a high suspended sediment load is allowed to pass through the orifices at a high velocity. An initial increase in yield is often followed by a gradual decrease in system performance, as particle abrasion wears pump impellers and removes protective finishes. If left untreated, pumping plant will become exposed to corrosion and/or the structural integrity of the conduit may be compromised.



## **2.3 Riverbed Construction and the Environment**

Any form of construction or maintenance activities in or near surface water has the potential to cause serious pollution and impact on water quality. In New Zealand, consent will be required to conduct work in and around surface water and groundwater that could have a detrimental effect on the local environment. Diversion of flows, construction of structures, and riverbed works all fall under this classification. The dewatering of excavations during construction in environmentally sensitive areas will also have an effect on other water users. The method used to convey contaminated water away from the site must be carefully considered. In some situations, the only method available may be to tanker off-site at a high cost (Environment Canterbury, 2012).

### **2.3.1 Silt**

Silt pollution damages the local ecosystem by killing aquatic life. Venables et al. (2000) and DETR (2000) suggest that the effects of disturbances to the riverbed can be minimised through the use of appropriate isolation techniques such as by-pass channels and coffer dams. However, consideration should be given to the riverbed material, likelihood of disturbances, and the conditions in which the work is to be conducted. Where possible, silty water pumped from the excavation should be pumped into surface storage and allowed to infiltrate the ground.

### **2.3.2 Pumping**

If excavations are inappropriately designed, water entering the excavation has the potential to become contaminated with harmful pollutants from the works. If this cannot be prevented and water is to enter the trench, consideration should be given to the location of the pump discharge outlet and the rate at which water discharges back into the river, the screening method (if any) to be used on the pump intake to prevent aquatic life from being destroyed, and the risk of erosion from discharging.

It is possible to pump directly to farm land. However, permission for this method of disposal must be granted by the council and landowner. To prevent surface ponding and runoff, the pumping rate must not exceed the soil infiltration rate. This rate will vary with topography, soil type, and land use.

### **2.3.3 Exposed Ground**

Environment Canterbury (2012) argues that ground works that require large areas of soil stripping significantly increase the risk of contaminated surface water run-off. It is therefore important to minimise the area stripped and the amount of vegetation removed. Inappropriately placed spoil and stockpiles can become contaminated from the increase in surface run-off, and should be protected accordingly. In sensitive areas, run-off from the area surrounding the site should be collected and stored in surface ponds where suspended fines are allowed to settle prior to disposal.

Filtration tanks provide a cost effective alternative to the use of temporary storage ponds, which can be limited in their use by the available space. Appropriate filter

materials in the form of coarse sands, geotextile fabrics or straw bales can be easily sourced, and should be frequently cleaned or replaced.

#### **2.3.4 Construction Works**

Venables et al., (2000) states that the introduction of construction plant to the site will inevitably generate contaminated water that will need to be treated or disposed of in a controlled manner. Hosing down of plant to remove potential contaminants should be conducted at least 10 m away from any watercourse (Environment Canterbury, 2012).

#### **2.3.5 Construction Materials**

Wash water from concrete or cement should never be allowed to enter the natural environment. Both cement and concrete have a strong alkaline base and can have a serious detrimental effect on the environment. Where possible, recirculation systems should be used to wash down construction plant that has been exposed to these materials, with the water being collected and stored in a sump to facilitate settlement of particle fines (DETR, 2000).

Strict guidelines govern the use and storage of oil and construction chemicals on site. If required, only small volumes of potentially harmful substances should be stored close to watercourses. Storage must be housed in a secondary containment system on an impermeable material/surface. The storage area must be away from any high risk area such as a well or spring, and located above the flood water level. Provisions such as sand should be put in place, and stored close to the hazardous substances for the event of a spill (Venables et al., 2000).

#### **2.3.6 Waste Management**

Contractors have a legal duty to ensure that any production waste is lawfully disposed of. Waste must be disposed of through an authorised body and be accompanied by a full description of the waste.

### 3 METHODOLOGY

This research project was conducted in three distinct phases, and employed a combination of quantitative and qualitative methods. The initial phase comprised of a literature review of current knowledge and practice.

The second phase involved a questionnaire, hosted on the internet and comprised of a combination of open (qualitative) and closed/pre-coded (quantitative) questions. The close-ended questions required a specific response, but that did not prevent subjective measurements from being made. Semantic differentiation scales, rating scales, grids and checklists are, at this stage, the preferred data capturing methods.

The third stage of the study involved a sequence of semi-structured interviews and site visits, with interviewees drawn from a process of selected sampling. Open-ended questions were employed.

The reasons for using interviews in addition to a questionnaire were (a) to triangulate data acquired from the interviews, (b) to expand the results of the questionnaire by exploring and expanding on some of the emerging issues, and (c) to explore the experiences of the sample population in relation to the relevant issues, revealed after the analysis of the data attained from the semi-structured interviews.

#### 3.1 Questionnaire

The aim of the online survey was to identify potential failure mechanisms and their frequency of occurrence. The survey focused on three specific aspects:

- Gallery operation and maintenance techniques;
- Gallery failure mechanisms; and
- Gallery construction environmental considerations.

All of the sampled contractors and consultants operating within the water sector were required to respond to specific questions pertaining to their experiences with the design and maintenance of infiltration galleries, and their opinions regarding the current methods practiced.

*Table 1: Questionnaire design*

Section	Contents of Section
Background Details	Section one comprises of background information which aims to retrieve information on the general particulars of the respondents.
Operation and Maintenance	Section two focuses on the gallery operators and how they maintain the infiltration system.
Failure Mechanisms	Section three focuses on identifying the most common cause of failure.
Environmental Considerations	Section four focuses on the contractor's use of pollution prevention guidelines (PPGs).

The questionnaire was conducted on the internet website, [www.surveymonkey.com](http://www.surveymonkey.com), <http://www.surveymethods.com> which offers an appropriate method for collating the

survey data. While constructing the questionnaire, an in-house pilot study was conducted. Ambiguous questions were identified and data capturing techniques assessed for their responsiveness.

### 3.2 Interviews

A series of unstructured (exploratory) telephone interviews was conducted with representatives from Marlborough District Council and with water users. The interviews consisted of unstructured, open-ended and informal questions. The purpose of the preliminary interview was to help develop an initial understanding about the issues surrounding gallery location, design, construction and operation.

The second phase of the research process was conducted using qualitative, semi-structured interviews. The aim was to penetrate the topical aspects identified from the preliminary interviews. Selected sampling was employed to establish a population.

Table 2 provides a summary of the interviewees. The interviewees originated from a mixture of public and private sector organisations that function within, or are dependent upon, the water sector. The majority of the interviewees were senior design technicians or experienced gallery operators.

*Table 2: Interview selective sample*

<b>Roles</b>	<b>Industry</b>	<b>Company Type</b>	<b>Investment Types</b>	<b>Interview Duration</b>
1. MDC Staff	Government	Regional Authority	Public	1 hour
2. Design Engineer	Construction	Consultancy	Civil, Geotech	1 hour
3. Design Engineer	Construction	Contractor	Civil, Geotech	1 hour
4. Gallery Operator	Agricultural	Viticulture	-	1 hour
5. Gallery Operator	Agricultural	Viticulture	-	1 hour

### 3.3 Method of Analysis

Descriptive statistical methods are simple methods of data analysis that facilitate a general overview of the results collated. As the sample obtained was small, the data presented will consist of actual figures as opposed to percentages.

## 4 RESULTS

This chapter embarks upon the process of exploring the results obtained from the data collection using the descriptive method. The order in which the results are presented does not correspond to the order of the questionnaire due to the use of ‘skip logic’, which also affected response rates to particular questions.

### 4.1 Questionnaire Supplemented by Site Visits and Interviews

All interviews were conducted informally, face to face. The interviews were open-ended. The site visits and interviews have been employed to supplement the questionnaire results, and have been integrated into the following questionnaire results.

#### 4.1.1 Background Details

This section of the questionnaire comprises of questions 1 to 5. The purpose of this section was to determine whether or not the selected population sample exhibited any homogenous characteristics. The results from the background details section are presented below:

*Table 3: Questionnaire sample population*

	<b>Role</b>	<b>Organisation Size (Number of Staff)</b>	<b>Experience (Years)</b>
1.	Property Owner	1-3	5+
2.	Property Owner	4-7	5+
3.	Property Manager	1-3	5+
4.	Property Owner	-	5+
5.	Property Manager	15+	5+
6.	Property Owner/Manager	4-7	5+
7.	Other	8-15	5+
8.	Property Manager	1-3	5+
9.	Property Manager	15+	5+
10.	Property Manager	-	5+
11.	Property Owner	4-7	5+
12.	Property Manager	15+	5+

#### 4.1.2 Gallery Performance

This section sought to establish how gallery users and operators perceive the performance of their galleries, and to identify the areas associated with the lowest performance levels.

Gallery performance in five critical areas was evaluated: flow rate, water quality, energy cost, maintenance cost, and reliability. Figure 7 identifies gallery maintenance cost and system reliability as having ‘poor’ performance. Eleven respondents also stated that their galleries energy consumption was ‘satisfactory’. Interestingly, six of the respondents indicated that their galleries flow rate performance was ‘excellent’.

## GALLERY PERFORMANCE

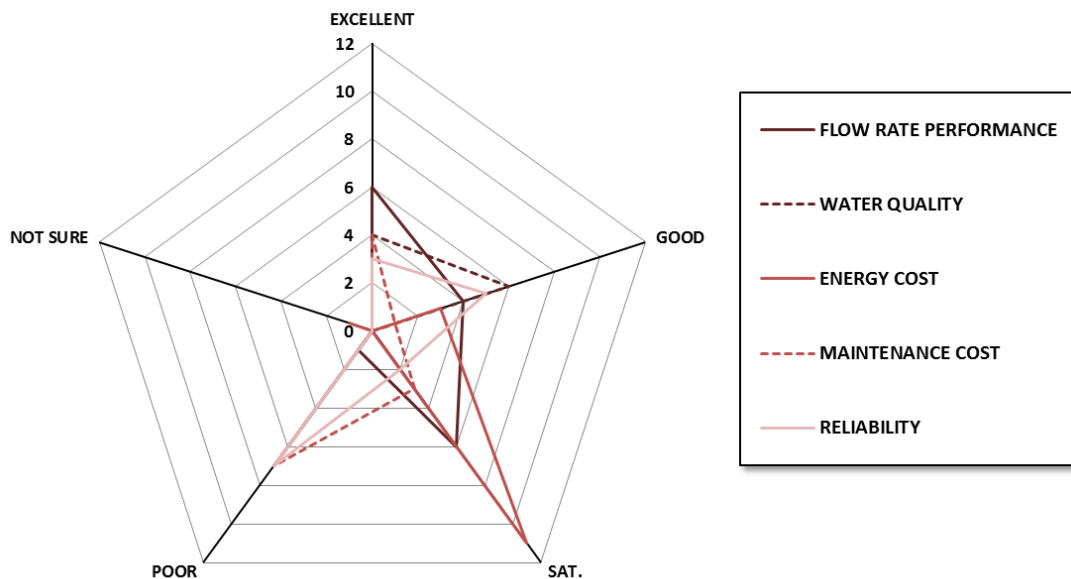

Figure 7: Gallery performance

### Summary of interviews and site visits

- a) While there are cases of complete system failure following a relatively short operating period, there are also many instances where performance has not been compromised since installation.
- b) All interviewees expressed concerns relating to the reliability of the gallery system installed. The poor performance of some galleries in the Marlborough district and the frequency of failure render many gallery users/operators anxious about the performance of their system and the consequences of failure.
- c) Gallery failure often occurs during peak irrigation season, when river water levels are low and irrigation demand is high. Conducting maintenance works during this period can have a detrimental impact on the local environment. Obtaining a consent to carry out remedial works can be difficult and a time consuming process. During this period, the window of opportunity to prevent drought damage is small, and the consequences of failure are high.
- d) As the demand for water in the Marlborough district has increased, the density of gallery systems has also increased, particularly along the Awatere River. This has already led to several legal disputes surrounding the actions of upstream river users and supply security.
- e) Even with natural filtration, (a key benefit of a gallery system), some users and operators experience periods of poor water quality, particularly during the summer months, when at times the Awatere River carries large volumes of fine suspended sediment.
- f) In general, galleries with a yield lower than 20 l/s have good flow rate performance and do not experience a significant reduction in yield over time. In contrast, galleries with a high design yield often experience a reduction in flow rate over time.

- g) A rapid reduction in yield was more common than a gradual decline. Most failures occurred following a significant event upstream or within the locality of the gallery which either completely scoured out the gallery structure, or resulted in the formation of a confining layer over the riverbed which restricted the movement of water through the ground.
- h) Gallery performance, in terms of maintenance cost, is influenced by the other four performance areas (water quality, flow rate, energy cost, and reliability). Generally, if a reduction in performance is experienced in any of these areas, remedial work will be required to improve the overall system performance, and there will be a subsequent cost associated with completing such work. All interviewees acknowledged that routine maintenance was essential in order to maintain system performance. However, the extent and magnitude of maintenance works was a major concern for many users and operators. The following is a summary of the main areas of concern:
- Maintenance often involves some form of work on the riverbed. Access to the riverbed is restricted to periods of low flow. However, during this period, the environmental impact of conducting works on the riverbed is at its highest.
  - Remedial work to improve the yield can involve ripping the riverbed in an effort to break up and/or remove any confining layer that may have formed. This can generate large quantities of silt/clay and/or suspended fines.
  - If the gallery system needs to be relocated, cleaned, increased in capacity, or the filter pack replaced, it usually involves significant cost.
  - The use of infiltration galleries does not guarantee good water quality. Low flows coupled with large volumes of fine (silt/clay) grained materials generate highly turbid water that is difficult to filter. Fines corrode casings and impellers, and cause pipelines and micro irrigation systems to become clogged.

#### **4.1.3 Performance Factors**

This section sought to establish which factors affected gallery performance. Five principal processes affect the performance and condition of a gallery system. They are:

- Physical;
- Chemical;
- Microbial;
- Operational; and
- Structural.

Physical processes, which include clogging and abrasion, were the most prevalent factors. Other performance factors identified can be attributed to operational and structural processes. No factors resulting from chemical or microbial processes were identified.

## FACTORS AFFECTING GALLERY PERFORMANCE

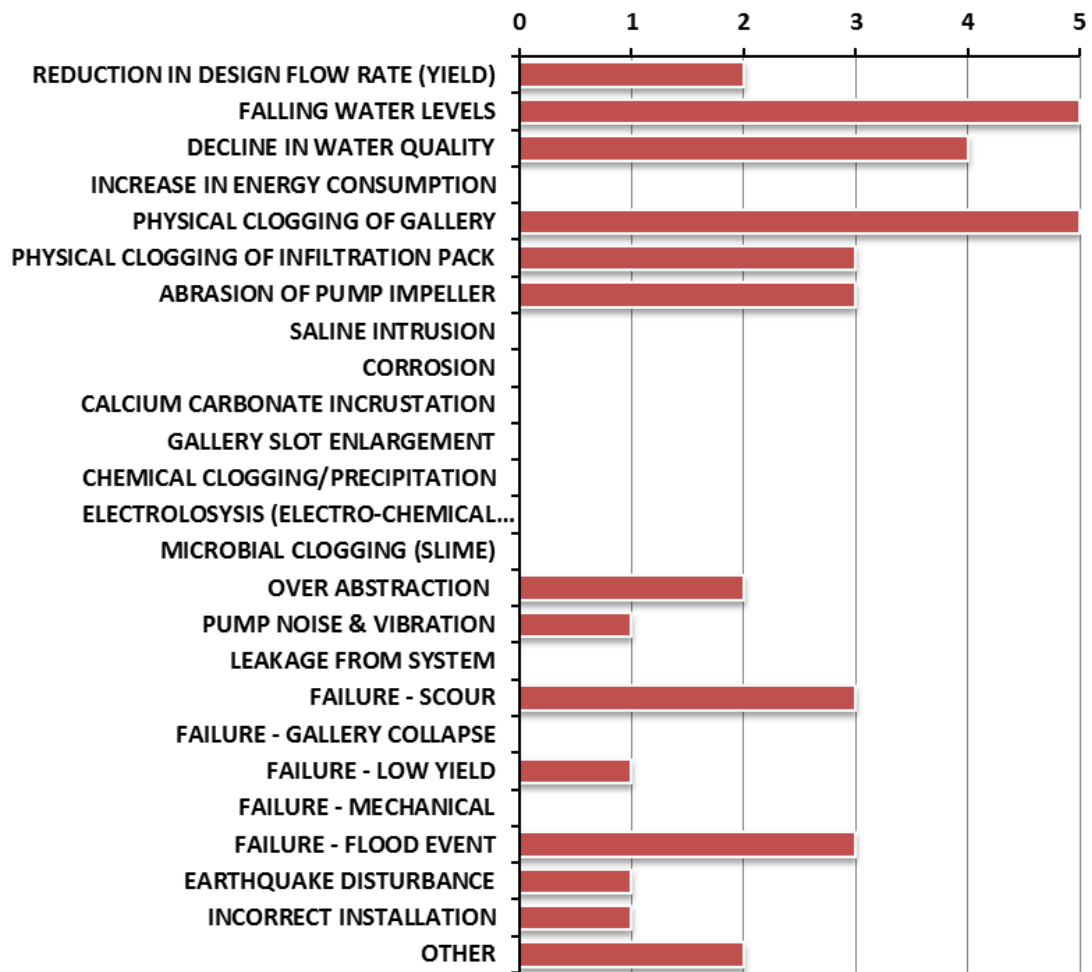

Figure 8: Factors affecting gallery performance

### Summary of interviews and site visits

- a) Clogging of the gallery and clogging of the infiltration pack were reoccurring themes throughout the interview process. This also supports the trends exhibited in Figure 8.
- b) Abrasion of the pump impeller and casings was a trait of most systems in the Marlborough region, and was always attributed to a decline in water quality.
- c) The following is a summary of the construction shortcomings identified:
  - The locally sourced infiltration pack material (example illustrated in Figure 9) may not be ideally graded for the screening required to maintain clean water and minimise the likelihood of clogging. Without examining specific installations, it is difficult to know.
  - There are significant risks associated with construction on, or close to, materials with high clay or silt content. Figure 10 illustrates the proximity of a cliff relative to a gallery installation. The presence of silt or clay can reduce infiltration rates, which will subsequently reduce the system's safe yield.



- Incorrect or poor installation generates operational risks and will often require future remedial work at an additional cost to the operator/user. Scour and undermining of the gallery structure was also a reoccurring theme. Many interviewees stated that the risks associated with a flood event and/or high river flows was not communicated efficiently during the design phase. In other cases, advice was given, but ignored because of cost implications to the owner.
- The depth of embedment was often determined by the depth to an impervious layer or, for exceptionally long galleries, the grade required to supply water to the sump. There was little discussion on bed-forms and the effect flow velocity and grade has on the expected bed profile – which may vary seasonally.
- The installations visited had all been designed to intercept horizontal (transient) flow, and were not designed to intercept any vertical recharge. All of the gallery slots were positioned perpendicular to the direction of flow on the upstream face of the conduit and, in some instances, plastic/PVC sheeting was placed directly above the intake structure to prevent vertical infiltration. While this is a valid design approach, these types of system are dependent upon a recharge zone that could be hundreds of metres or several kilometres upstream. Therefore, the performance of these structures is dependent upon favourable conditions upstream, and can be influenced by human activities.
- Some of the systems that were designed to intercept horizontal flow have experienced a reduction in yield as the sub-surface stream migrates or diminishes. In an effort to increase yield, diversion channels have been constructed to route water over the intake structure at an additional cost to the user/operator.



*Figure 9: Washed infiltration pack material*



*Figure 10: Presence of clay*

#### **4.1.4 Frequency of Maintenance**

This section sought to establish the frequency of routine maintenance and rehabilitation. The most frequently performed maintenance was servicing pumps, followed by gallery yield test and inspection of water quality. The most infrequently performed maintenance tasks were flushing and air blasting.

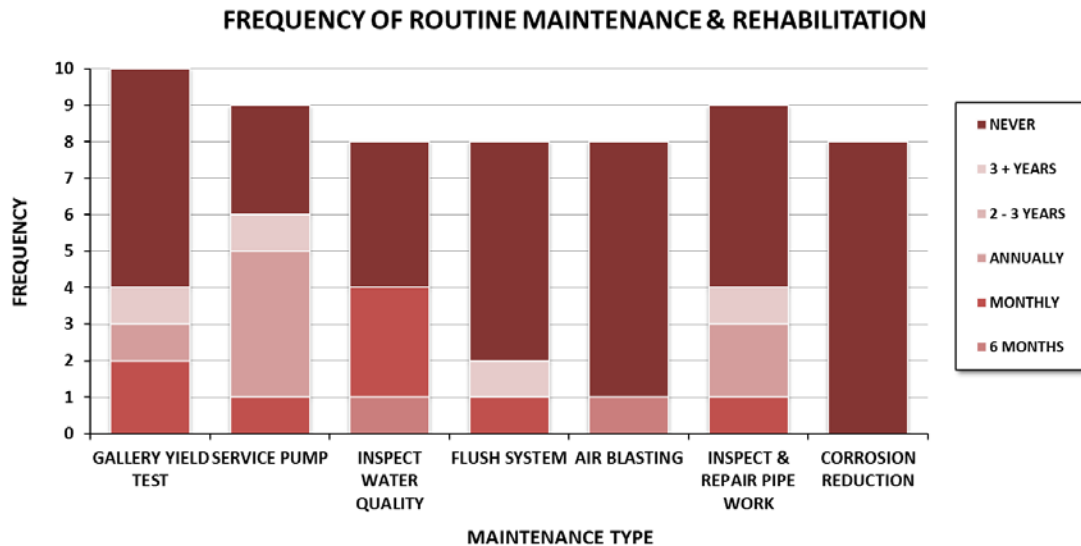

Figure 11: Frequency of routine maintenance and rehabilitation

### Summary of interviews and site visits

- a) All interviewees understood the importance of conducting routine maintenance. The general consensus was that the frequency of maintenance was high and often costly.
- b) Many users/operators questioned the viability of installing infiltration galleries given the ongoing and uncertain maintenance costs.
- c) None of the installations visited were capable of air blasting or back flushing the infiltration pack to remove fines.
- d) Ripping is common practice and is used to break up the riverbed in an effort to encourage natural infiltration and recharge of the local groundwater system.
- e) A number of gallery users have consent to divert flow over the gallery to maintain yield. The success of this initiative was not clear, particularly for systems designed to intercept horizontal flow.

## 5 DISCUSSION

### 5.1 Infiltration Galleries in the Marlborough District

Before discussing gallery failures in the Marlborough district, it should be noted that, while the rate of gallery failures has been significant, many galleries have, and still continue, to operate successfully on many of the rivers that pass through the Marlborough district.

The use of galleries on rivers such as the Wairau and Awatere is not uncommon, and their popularity has increased as demand for clean water for irrigation rises. Demand for clean water has been largely fuelled by the growth of viticulture in the region, and the accompanying use of sprinkler or drip irrigation systems. Spray or drip irrigation systems require a high standard of water quality to prevent the outlets and reticulation system from becoming clogged. Of the various types of intake available, galleries are appealing because they have the ability to provide natural filtration. So long as they are designed correctly and only installed in suitable environments, galleries can provide a cost effective means of abstracting and filtering river water.

All of the rivers discussed in this report are braided rivers characterised by multiple interweaving channels, high sediment loads, and rapid and frequent variations in flow rate. Any structure, including a gallery, placed in this environment is susceptible to localised erosion and scour, and at risk of undermining.

The high proportion of failures attributed to environmental risk factors is not unexpected for such a dynamic environment. It should always be borne in mind that it is impossible to design a structure that will never fail. Only through professional design methods and controlled construction can the likelihood of failure be reduced to an acceptably small value. In the case of an infiltration gallery, perfect certainty surrounding the likelihood of failure cannot be achieved because the gallery must be designed to meet conflicting design requirements surrounding water quality, yield and cost.

It appears that limited investigative work has been conducted on suitability of installing infiltration galleries in the Marlborough district, particularly in the sediment prone Awatere River. Although test holes are almost always used to indicate the presence or not of water, detailed investigation of hydrogeological aspects of the environment are rarely carried out.

From a design perspective, the feasibility of various intake methods should always be investigated prior to a decision being made on the type of intake structure to be used. The 'one solution fits all' approach has, in this instance, forced many gallery users/operators to finance expensive maintenance programmes and take on high and unforeseen operating costs. For some gallery users, there has also been little realisation of gallery benefits in terms of improved water quality.

Galleries have been constructed in some questionable locations. In some instances, the decision on where to install a water intake has, unfortunately, been limited by factors such as access to a river and by the activities of other river users. These limiting factors need to be weighed against alternatives when determining the type of intake.

Construction on a meander will introduce further complications. Structures should be located on straight sections of rivers where there is less risk of erosion. The outside of meander bends where erosion naturally occurs should be avoided. Although it is not always possible, the inside of bends, where sediment tends to accumulate, should also be avoided. River sections confined by steep cliffs or embankments can provide greater flow certainty (i.e. increased probability of intercepting sub-surface flow), but can be at risk from increased sediment loads as embankments are eroded.

Issues surrounding the legal rights to supply and the impacts of upstream activities on river users already exist, and could become even more prominent in future years. The aquifer supplying a gallery system is often assumed to be connected directly to the overlying river. While this is a reasonable assumption to make when considering a system in isolation, the introduction of multiple systems along the same river course increases the complexity of the situation, and can produce difficulties in establishing the radius of influence for each system and determining the impact of upstream abstraction.

An abstraction consent only grants the consent holder permission to abstract a specified quantity of water from a stated source. It does not guarantee the quality of the water or that the required amount will always be available. Gallery systems in Marlborough are usually expected to adhere to the abstraction restrictions associated with the connected river supply, stipulated in the resource consent. However, the movement of water through the ground does not follow the same flow patterns and seasonal trends exhibited by a surface water body.

## **5.2 Gallery Failures in the Marlborough District**

Galleries are likely to experience a reduction in yield because of falling water levels or because of clogging. Falling water levels can be the result of upstream activities such as abstraction. Whilst the rules and regulations that govern abstraction from a surface water body have been developed to safeguard the interests of all river users by guaranteeing minimum flows, the same rules are difficult to apply to a groundwater system.

Many of the galleries on the Awatere River have been designed to intercept horizontal flows and seek to exploit transient flow systems. This is evident in as far as most galleries do not traverse the main water course but extend the length of the exposed bed. Polyvinyl sheeting has also been used on some installations to actively prevent vertical recharge in an effort to prevent clogging of the infiltration pack. This suggests that for most galleries in the Marlborough region, the intended primary recharge zone supplying the groundwater system is upstream of the installation. This introduces a large element of uncertainty into the design because the precise location of the recharge zone is unknown.

Confined gallery systems that are dependent upon horizontal flow from a distant recharge zone are susceptible to several river management risks, such as the following:

- a) Interference from upstream gallery users abstracting from the same groundwater system.

- b) The dynamic morphology of a braided river. Changes to upstream erosion and accretion patterns will influence the recharge area and subsequently increase/decrease the potential yield.
- c) Cleaning of the infiltration pack is difficult and can only be achieved by excavating and refilling the surrounding area.

Clogging (a reduction in permeability) is the most common form of gallery failure in the Marlborough district. It is caused by a number of factors:

- **Inter mixing of aquifer horizons:** For all of the sites visited, the presence of clay (papa) within the local vicinity was apparent. Clay strata, disturbed during construction, can mix with more permeable horizons to generate a heterogeneous anisotropic layer around the conduit, which restricts flow into the gallery.
- **Inter mixing of aquifer and infiltration pack:** This is the result of poor installation. Individually, the materials may have a reasonable degree of permeability. However, when combined, permeability may be significantly reduced.
- **Migration of fines from the formation into the infiltration pack:** The selection of an appropriate filter pack is a critical aspect of the design process. Most of the galleries visited used washed gravel, sourced from the riverbed. Locally sourced fill is desirable because it reduces capital costs. However, it may not always be entirely suitable because the grading does not always prevent fines from entering the filter pack.
- **Clogging by organic material:** The biggest problem is willow roots. Willows are often seen growing over the top of or close to galleries and the roots are known for growing into the filter pack and sometimes into the gallery pipe itself. Willows should be kept at least 30 m away from galleries.

Vertical well systems are usually installed with a stainless steel screen with a slot size less than half of  $d_{85}$ . The purpose of the screen is to prevent fines from entering the system once the well has been fully developed. Stainless steel well screens can represent a significant proportion of the final cost for vertical wells (> \$1000/m) but this precaution is justified by the protection a screen provides for pumping plant and the relatively short lengths required. Vertical wells are also well developed before abstraction begins. This helps remove material from the borehole which helps protect the pumping plant during operation. Galleries on the other hand, are in essence large diameter shallow wells, and cannot be developed as efficiently and effectively as vertical wells.

Pump impeller wear is commonly reported, and there are also many cases of corrosion damage to the reticulation system as a result of abrasion from high velocity particle laden water. Particle ingress can be attributed to many factors, including inappropriately large slots and/or a poorly designed filter pack. Many of the galleries installed on the Awatere River consist of a PVC pipe with machine cut slots, which are about 4 mm in width, similar to the conduit depicted in Figure 12. Whether this slot size is appropriate will depend on filter pack design.



*Figure 12: Gallery conduit with machine cut perforations*

### **5.3 Galleries and the Environment**

This section describes how installation and maintenance of gallery systems have led to pollution and adverse environmental impacts.

The most common pollutant in the Marlborough region is fine grained materials. Sediment-laden discharge water is the product of groundwater operations or erosion of exposed material on site. There is a common misconception that sediment-laden water is harmless to the environment. However, fine grained materials can seriously damage the aquatic system in a number of ways:

- Injure fish by its abrasive action
- Clog the gills of fish
- Destroy spawning sites and disrupt the local ecosystem
- Reduce light levels and prevent growth
- Coat the leaves of aquatic plants and prevent growth
- Induce flooding

The best and most effective method for managing suspended solids in discharge water is to address the problem at its source, and to put into place the necessary precautions during the design stage by ensuring that the construction process can be conducted in a way that limits the volume of sediment entering the river.

It was evident from discussions with water users and contractors that, in the Marlborough district, sediment-laden water is managed by controlling its time and entry into the river system, as opposed to preventing it entering altogether. That is acceptable practice if the discharge water is cleaner than the river water at the time.

The problem of suspended sediments may be made worse when there is erosion of the riverbed or embankment by discharge (see Figure 13). Management techniques such as using sediment traps/ soak pits downstream of the discharge point to capture solids (as was the case for the discharge shown in Figure 13) are good practice. Alternatively, geotextile fabrics, gabion baskets or stone mats can be used to dissipate the energy of the discharge and reduce potential erosion.



*Figure 13: Discharge during a gallery test*

In addition to fine grained materials, contaminants and pollutants such as oil are at risk of entering the river system every time riverbed construction or maintenance works (such as ripping) are carried out. Spills or leaks can occur while plant is being operated on or close to the riverbed.

Water pumped or abstracted from a gallery or from a groundwater control operation used during the construction of a gallery is classified as trade effluent. As such, a formal consent is usually required to discharge it back into the environment. All gallery works requiring dewatering should apply for consent to discharge to land or water as part of the consenting process, and mitigation measures should be specified. For some construction projects, no application is made for a discharge consent, and the local authorities will only become aware of a discharge problem when alerted to a pollution incident.

## 5.4 Water Supply Options

There is no doubt that galleries can provide clean sources of water for irrigation and other purposes. However, there are risks involved that need to be understood and managed.

Property owners and managers need to be well-informed and consider all water supply options when considering abstraction methods. In some cases, a gallery will be the optimum choice. In other cases, alternative solutions should be considered and costed. Costs should include initial capital expenditure and ongoing operating costs.

Alternatives include, but are not limited to:

- **Individual wells.** As a vertical well casing is often installed as a collection pump at a gallery abstraction point, it should be assessed to see whether it is potentially capable of providing the required yield without an attached gallery. A vertical well is more likely to provide a long-term reliable yield than a gallery.
- **Well fields.** Sometimes individual wells do not produce sufficient yields for the owner's needs. Multiple wells can be used to increase overall yield.
- **Direct surface takes.** Many intakes on rivers are of this type. They are normally lower cost systems that require regular on-going maintenance but

have the advantage that they can be relatively easily maintained. All of the infrastructure is where it can be seen and easily accessed. The biggest challenge in rivers such as the Awatere is that pumping times are determined by irrigation demand timing, and it is often necessary to pump dirty water. Pumping dirty water adds significant challenges in filtering water for irrigation. It also results in accelerated pump wear.

- **Pump to storage.** This is a variation on a direct surface take. The greatest difference is that water can be pumped at a lower rate into storage and if planned properly, can avoid pumping water at times water quality is low. Because storage can be expensive to construct, this option may be the best options for systems involving multiple users.

## 6 CONCLUSIONS AND RECOMMENDATIONS

In conclusion:

- 1) Insufficient consideration has been given to the rationale or feasibility of using infiltration galleries in the Marlborough district, despite the fact that good advice is often given. Intakes are bespoke and should be designed individually to suit the individual site, the characteristics of the river, the flow regime, and abstraction requirements. There are no hard and fast rules for intake design because the complexity of the environment produces a large number of variables which prevents the use of a standard solution. The following is recommended:
  - a) Prior to engaging with a consultant or contractor, the client should clearly define the rationale and justification for an intake structure in terms of evaluating the benefits, cost and risks.
  - b) The designer should always conduct a short feasibility study before any decision is made regarding the type of intake structure to be designed. The feasibility study should include:
    - An evaluation of options;
    - Benefits of each option;
    - Risks of each option;
    - Whole life cycle costs (capital, operational & maintenance);
    - Assumptions made for each option;
    - Constraints for each option;
    - Dependencies for each option; and
    - The justification for the final intake type.
- 2) The density and quantity of galleries in the Marlborough district is concerning. Many users are wholly dependent upon this method of intake. However, the risks associated with over-abstraction from localised groundwater systems, access to water, upstream activities, sediment control and management, environmental management, operational costs, maintenance costs, and loss of agricultural production are high, and more rigour is needed during the process of designing, consenting, and installation to prevent environmental damage.



Diversification is one of the most established methods of managing idiosyncratic risk. Users who currently operate a variety of intake system types have less risk exposure than those who are dependent upon several gallery intakes to meet their water demands. Water users should actively seek to diversity their operations and seek to appreciate the risks associated with applying a standard solution to a complex and dynamic river system.

- 3) The presence of clay (papa) within the vicinity of an intake represents a significant risk to the ongoing performance of any infiltration system. Clay has a low permeability and can significantly reduce the performance of a gallery system if a confining layer is allowed to develop, or if fines are allowed to migrate into the infiltration pack. Rehabilitation of a gallery system to relieve the effects of clay intrusion is expensive, poses many risks to the local environment, and can be prevented through correct and efficient design. Installing any form of infiltration system in this environment is risky, and it is recommended that all other intake options be explored before opting for an infiltration system.
- 4) The majority of galleries installed in the Marlborough region have been designed to intercept horizontal flow from sub-surface streams or transient flows. This presents several key performance and maintenance issues:
  - a) The precise location of the aquifer recharge zone is unknown. This encourages activities such as ripping of the riverbed to increase the rate at which infiltration occurs and subsequently recharges the groundwater system. Ripping of the riverbed presents risks to the local environment and downstream river users.
  - b) Water is often diverted over the gallery screens to increase vertical flow. This can require extensive riverbed works. The effectiveness of this approach with systems designed for horizontal flow is unknown.
  - c) The activities of all river users will inevitably have an impact on those operating further downstream. A river reach associated with a high density of galleries presents many risks to the users and operators who may be dependent upon an interconnected and highly dynamic aquifer system for their water supply. It should also be noted that shallow aquifers can experience a significant change in their properties (type, transmissivity, saturated depth, and storativity) following a storm event. Therefore, a gallery system should be considered less reliable than a surface water system.
- 5) Experience has shown that where infiltration systems perform poorly, cause is rarely simply incorrect calculations, or even errors in permeability selection. The problem often arises from an inappropriate appreciation of the natural processes present – absence of preliminary work, such as a site investigation, is often cited as the main reason for this lack in appreciation, but it may also arise from poor interpretation of the groundwater risks when formulating ideas regarding the dynamics of the groundwater system. Designers may also be tempted to fit the ground conditions to match their own interpretation of the processes present based on previous design experience and not site specific information; in which case the installed system is less likely to be successful.

- 6) Even when thorough site investigations are carried out, in some circumstances, the complexity of the ground conditions may mean that the design of a system dependent upon a groundwater system cannot be finalised, other than very tentatively. A progressive design approach may be required.
- 7) An appropriate design should allow the inter-relationship between groundwater flows in the various strata at a site to be identified. This will influence the type of system to be installed and the maximum yield that can be expected.
- 8) There is a significant need to identify potential aquifer boundary conditions, such as sources of groundwater recharge, when developing an appreciation of the natural processes present. Permeable gravel lenses or “shoestrings”, which may be present in alluvial or fluvio-glacial deposits following old buried stream beds, can be very difficult to detect in borehole investigations. This presents a significant risk for designs that may be dependent on them for the majority of their yield.
- 9) Water users should consider forming water user groups and investing in resilient infrastructure capable of securing the delivery of a reliable and good quality water supply. To reduce the operational costs, maintenance costs, and environmental impact of abstraction, all human activity on the riverbed must be minimised. This can be achieved by using a bank-side structure to store, filter and pump water from. Bank-side structures facilitate good access for routine maintenance, and are at a lower risk of flood damage than an in stream structure.

Storage will improve supply reliability, prevent the need to pump directly from the river when water quality is particularly poor, and can also be incorporated into an onsite water treatment facility, which may include a stilling pond and/or a mechanical filtration system. Removable pumping plant, located on the riverbed, should be considered expendable but a necessary and known failure point within the system. This will provide greater certainty surrounding where and when failure will occur. Water users will then be in a position to effectively plan and manage maintenance activities and costs with minimal effects on the environment.

- 10) It has been concluded that successful gallery projects should involve the following stages, which may be carried out by one or several organisations:
  - a) Maintenance and monitoring assessment of potential groundwater risks during the design of permanent and temporary works, including environmental questions, where possible, selecting appropriate techniques at an early stage.
  - b) Execution of an appropriate site investigation.
  - c) Consultation with the appropriate environmental regulator or authority to obtain the necessary information and consents.
  - d) Use of design methods that concentrate on natural processes present, and select appropriate permeability values.

- e) Methods of analysis and calculations that use sensitivity or parametric analyses to assess the effect of variations in permeability or boundary conditions. It is not realistic to expect a set of unique answers from calculations, and it is better to predict a range of values for flow rate.
- f) Design and specification of a flexible system that can be easily modified to meet the range of probable outcomes.
- g) Supervision of the installation of the system to make sure it is carried out correctly.
- h) Monitoring and analysis of the performance of the system at start up and during the initial testing/pumping period, in order to make a prompt response if modifications are necessary.

## 7 REFERENCES

- Azizi, F. (2007). *Physical Behaviour in Geotechnics*. Plymouth: University of Plymouth.
- BRE. (2005). *Soakaway Design*. London: Building Research Establishment.
- CIRIA. (1994). *Groundwater Control Design and Practice*. London: CIRIA.
- CIRIA. (2007). *The Rock Manual* (2 ed.). London: Construction Industry Research and Information Association.
- DETR. (2000). *Controlling the Environmental Effects of Recycled and Secondary Agregates Production*. London: Department of the Environment, Transport and the Regions.
- Driscoll, F. G. (1986). *Groundwater and Wells* (2 ed.). London.
- DTI. (1992). *Guidelines for the Environmental Assessment of Cross-Country Pipelines*. London: Department of Trade and Industry.
- Environment Canterbury. (2012). *Erosion and Sediment Control Guidelines for Small Sites*. Christchurch: ECan.
- Falkland, A. (1999). *Hydrology and Water Resources of Small Islands: A Practical Guide*. UNESCO.
- Hamill, L. (2006). *Understanding Hydraulics*. Basingstoke, UK: Palgrave Macmillan.
- Hemphill, R. W., & Bramley, M. E. (1989). *Protection of River and Canal Banks*. London: Butterworths.
- Howsam, P., Misstear, B., & Jones, C. (1995). *Monitoring, Maintenance and Rehabilitation of Water Supply Boreholes*. London: Construction Industry Research and Information Association.
- Jewell, R. A. (1996). *Soil Reinforcement with Geotextiles*. London: Construction Industry Research and Information Association.
- Lauterjung, H., & Schmidt, G. (1989). *Planning of Water Intake Structures for Irrigation or Hydropower*. Eschborn: Deutsche Gesellschaft fur Technische Zusammenarbeit.
- Ministry of Forests, Lands & Natural Resource Operations. (2012). *Design Guidelines for Rural Residential Community Water Systems*. Government of British Columbia, Canada.
- Reeve, D., Chadwick, A., & Fleming, C. (2004). *Coastal Engineering*. Oxon: Spon Press.
- SEPA. (2008). *Intakes and Outfalls*. Scottish Environment Protection Agency.
- SEPA. (2009). *Temporary Construction Methods*. Glasgow: Scottish Environment Protection Agency.
- Sommerville, S. H. (2005). *Control of Groundwater for Temporary Works*. London: Construction Industry Research and Information Association.
- UNEP. (2012). *Intergrated Water Resources Management Planning Approach for Small Island Developing States*. UNEP.
- Venables, R., Newton, J., Westaway, N., Venables, J., Castle, P., Neale, B., & Short, D. (2000). *Environmental handbook for building and civil engineering projects*. London: Construction Industry Research and Information Association.
- Water Research Centre. (1990). *Design Guide for Marine Treatment Schemes*. London: Water Research Centre.
- WEDC. (2011). *Surface Water Intakes*. Loughborough, UK: Loughborough University.